



Edition : 3.0  
Date: (06/24)

## Instruction Manual

# HYDRAULIC ENGINE CRANE HC-1.25T

Order Code: (A350)

1.0 MACHINE DETAILS

<b>MACHINE</b>	HYDRAULIC ENGINE CRANE
<b>MODEL NO.</b>	HC-1.25T
<b>SERIAL NO.</b>	
<b>DATE OF MANF.</b>	

DISTRIBUTED BY



www.machineryhouse.com.au  
www.machineryhouse.co.nz



**PRODUCT SPECIFICATIONS**

Model: HC-1.25T      Nett Weight: 92kg  
Capacity: WLL 1250Kg      MFG Date:

Serial No:

www.machineryhouse.com.au      www.machineryhouse.co.nz  
Made in China



**NOTE:**

In order to see the type and model of the machine, please see the specification plate. Usually found on the back of the machine. See example (Fig.1)

(Fig.1)

**2.0 SPECIFICATIONS**

These cranes accept a wide variety of engines and transmissions and can also be used to lift machines or other heavy items. This HC-1.25T engine crane has an 8-tonne long stroke lifting ram with a double acting pump. The jib extends to four different positions with the desired lifting capacity of 310kg, 625kg, 930kg or 1250kg and secured by a single locking pin. Swivel castors provide excellent manoeuvrability and quick fold up legs saves on storage space in the workshop.

Max. Load Capacity .....	1250kg
Lifting Capacity Position 1 .....	1250kg
Lifting Capacity Position 2 .....	930kg
Lifting Capacity Position 3 .....	625kg
Lifting Capacity Position 4 .....	310kg
Max. Lift Height Position 1 .....	1870mm
Max. Lift Height Position 4 .....	2300mm
Nett Weight .....	92kg

(Full load capacity rating is also on the specification plate on the engine stand (Fig. 2))



(Fig.2)

### 3.0 SAFETY PRECAUTIONS



**DO NOT** use this machine unless you have been instructed in its safe use and operation and have read and understood this manual. It is the responsibility of the owner to make sure all personnel read this manual prior to using the device. It is also the responsibility of the device owner to keep this manual intact and in a convenient location for all to see and read. If the manual or product labels are lost or not legible, they need to be replaced before operating.

#### **THE NATURE OF HAZARDOUS SITUATIONS WARNING!**

The use of portable automotive lifting and support device is subject to certain hazards that cannot be prevented by mechanical means, but only by the exercise of intelligence, care, and common sense. It is therefore essential to have owners and personnel involved in the use and operation of the equipment who are careful, competent, trained, and qualified in the safe the operation of the equipment and its proper use. Examples of hazards are dropping, tipping or slipping of loads caused primarily by improperly securing loads, overloading, off-centered loads, use on other than hard level surfaces, and using equipment for a purpose for which it was not designed.

#### **METHODS TO AVOID HAZARDOUS SITUATIONS WARNING!**

- Read, study, understand and follow all instructions before operating this device.
- User and bystanders must wear eye protection that meets the Australian and New Zealand standards.
- Inspect the engine crane before each use. Do not use if damaged, altered, modified, in poor condition, or has loose or missing hardware or components. Take corrective action before using the engine crane.
- Do not overload. Overloading could cause damage to the engine crane.
- Never use this crane on uneven floor as this could result in the crane tipping over.
- Always lock the legs and jib in position before lifting a load.
- The nuts and bolts supplied with the crane are all high strength and should not be substituted for inferior types.
- Before each use ensure that all the nuts and bolts are correctly fitted and tight.
- Never exceed the safe working loads indicated on the jib.
- Only attachments and/or adapters supplied by the manufacturer should be used.
- Do not use the crane to dolly or transport engine.
- Do not crawl under engine or place any part of your body under engine at any time.
- Refer to engine manufacturer's service manual for proper lifting points, mounting points and bolt sizes. Mounting bolts should be torqued at appropriate amount to maintain load.

#### **CONSEQUENCES OF NOT AVOIDING HAZARDOUS SITUATIONS WARNING!**

Failure to read this manual completely and thoroughly, failure to understand its OPERATING INSTRUCTIONS, SAFETY WARNINGS, MAINTENANCE INSTRUCTIONS and comply with them, could cause accidents resulting in serious or fatal personal injury and/or property damage.



#### **ENVIRONMENT PROTECTION**

Recycle unwanted materials instead of disposing of them as waste. All tools, accessories and packaging should be sorted, taken to a recycling centre and disposed of in a manner which is compatible with the environment. When the product becomes completely unserviceable and requires disposal, drain any fluids (if applicable) into approved containers and dispose of the product and fluids according to local regulations.

### 4.0 OPERATING INSTRUCTIONS

**SETUP INSTRUCTIONS** *This safety warning is used for the SETUP INSTRUCTIONS section of this manual to alert you to potential personal injury hazards. Obey all instructions to avoid possible injury or death.*













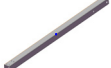

- Refer to your vehicle service manual to verify that the engine weight does not exceed the maximum engine crane load rating, suggested engine mounting tips, proper size bolts and the engine's center of balance. The engine's center of balance must be aligned with lifting centre point and appropriate lifting slings and chains used.
- Load must be directly under the Engine crane before lifting. Only use approved lifting chains & slings. Before removing or installing your engine, always apply the handbrake and use wheel chocks to prevent vehicle from rolling. Only move the engine crane with the load as low as possible to the ground to prevent the engine crane tipping due to its high centre of gravity. Keep as much of your body as possible out from underneath the vehicle when reinstalling the engine. Prevent pinching by releasing pressure in the ram leaving boom all the way down when not in use.
- This engine crane has a folding feature that can save space and make storage easy. Remove the pins so the 2 feet can be folded up vertically. The pins and clips can be stored in the open holes.

#### PREVENTATIVE MAINTENANCE

1. Always store the engine crane in a well protected area where it will not be exposed to inclement weather, corrosive vapors, abrasive dust, or any other harmful elements. The engine crane must be cleaned of water, snow, sand, grit, oil, grease or other foreign matter before using.
2. Lubricate the wheels, casters, fittings and rotating shaft with a general purpose grease.
3. Every engine crane owner is responsible for keeping the engine crane label clean and readable. Use a mild soap solution to wash the external surfaces of the stand.
4. Inspect the crane before each use. Do not use the crane if any component is cracked, broken or bent. Do not use the crane if it has loose or missing hardware or components, or is modified in any way. Take corrective action before using the crane again.

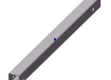
## 5.0 PARTS LIST - DIAGRAM

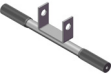
Part No.	Description	Qty	
1	Base	1	
2	Boom	1	
3	Main Support	1	
4	Leg	2	
5	Lock Pin	4	
6	Support Strap	2	
7	R-Pin	4	
8	Lifting Shackle/Bracket	1	
9	3.5" Caster	4	
10	3" Caster	2	
11	8T Long Ram Jack	1	
12	Jack Handle	1	
13	Boom Extension	1	
14	Bolt M16x100mm	2	
15	Bolt M16x110mm	2	
16	Handle	1	

Part No.	Description	Qty	
17	Bolt M16x90mm	1	
18	Bolt M16x80mm	1	
19	Bolt M14x100mm	2	
20	Bolt M12x80mm	1	
21	Bolt M8x20mm	16	
22	Bolt M8x12mm	8	
23	Nut M16	6	
24	Washer 16mm	6	
25	Nut M14	3	
26	Washer 14mm	3	
27	Nut M12	1	
28	Washer 12mm	1	
29	Lock Washer 12mm	1	
30	Nut M8	16	
31	Lock Washer 8mm	24	
32	Washer 8mm	24	
33	Bolt M14x90mm	1	

# 6.0 ASSEMBLY INSTRUCTIONS

**6.0**  
Bolt four 3.5" caster wheels (#9) to the bottom of the base (#1) using 8 x M8x20mm bolts (#21), nuts (#30), washers (#32) & lock washers (#31) for the rear two wheels and 8 x M8x12mm bolts (#22), washers (#32) & lock washers (#31) for the front two wheels as shown.

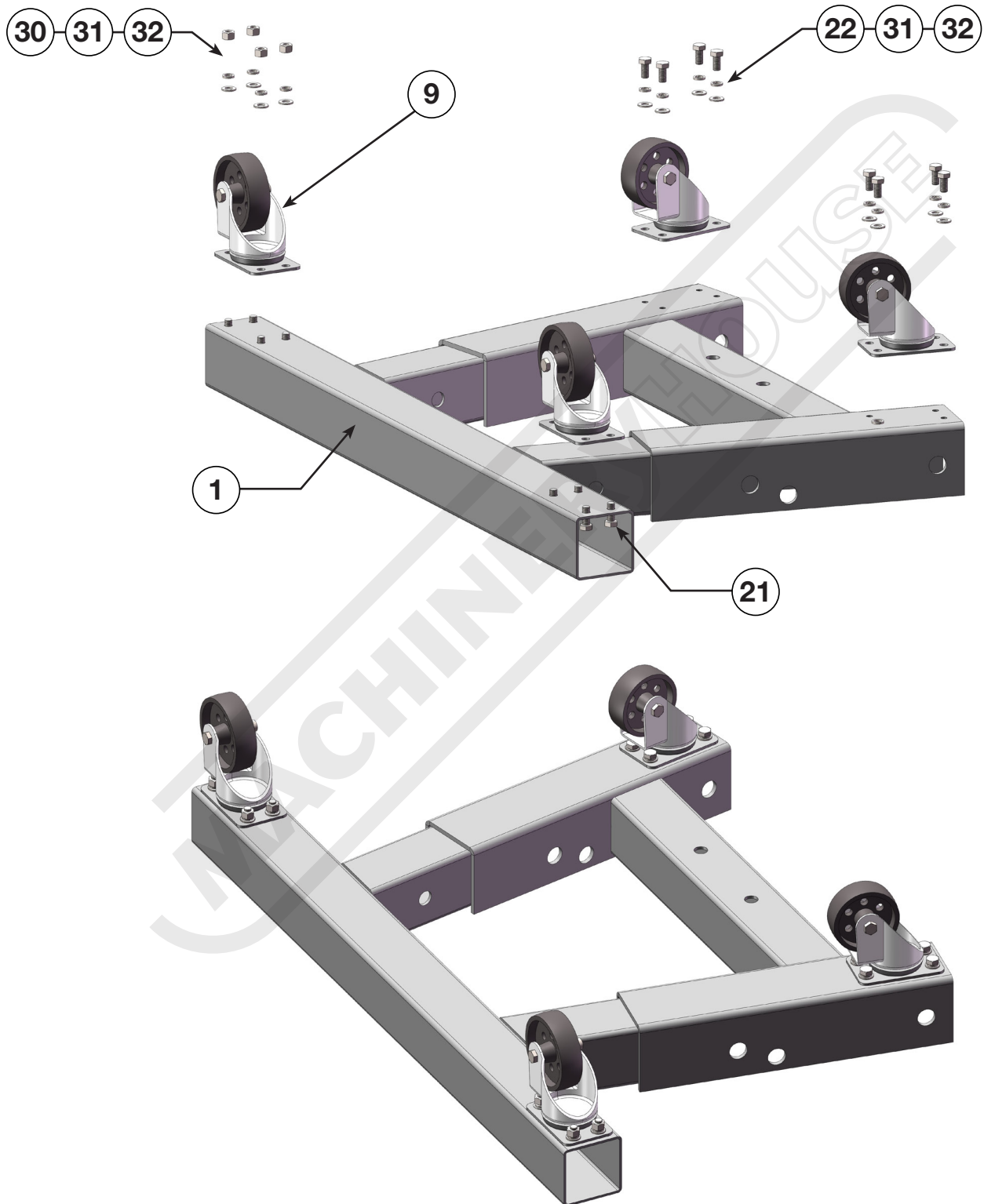

**6.0 ASSEMBLY INSTRUCTIONS**

**6.1**  
Bolt a 3" caster wheel (#10) to the bottom of each leg (#4) using M8x20mm bolts (#21), nuts (#30), washers (#32) & lock washers (#31) as shown.

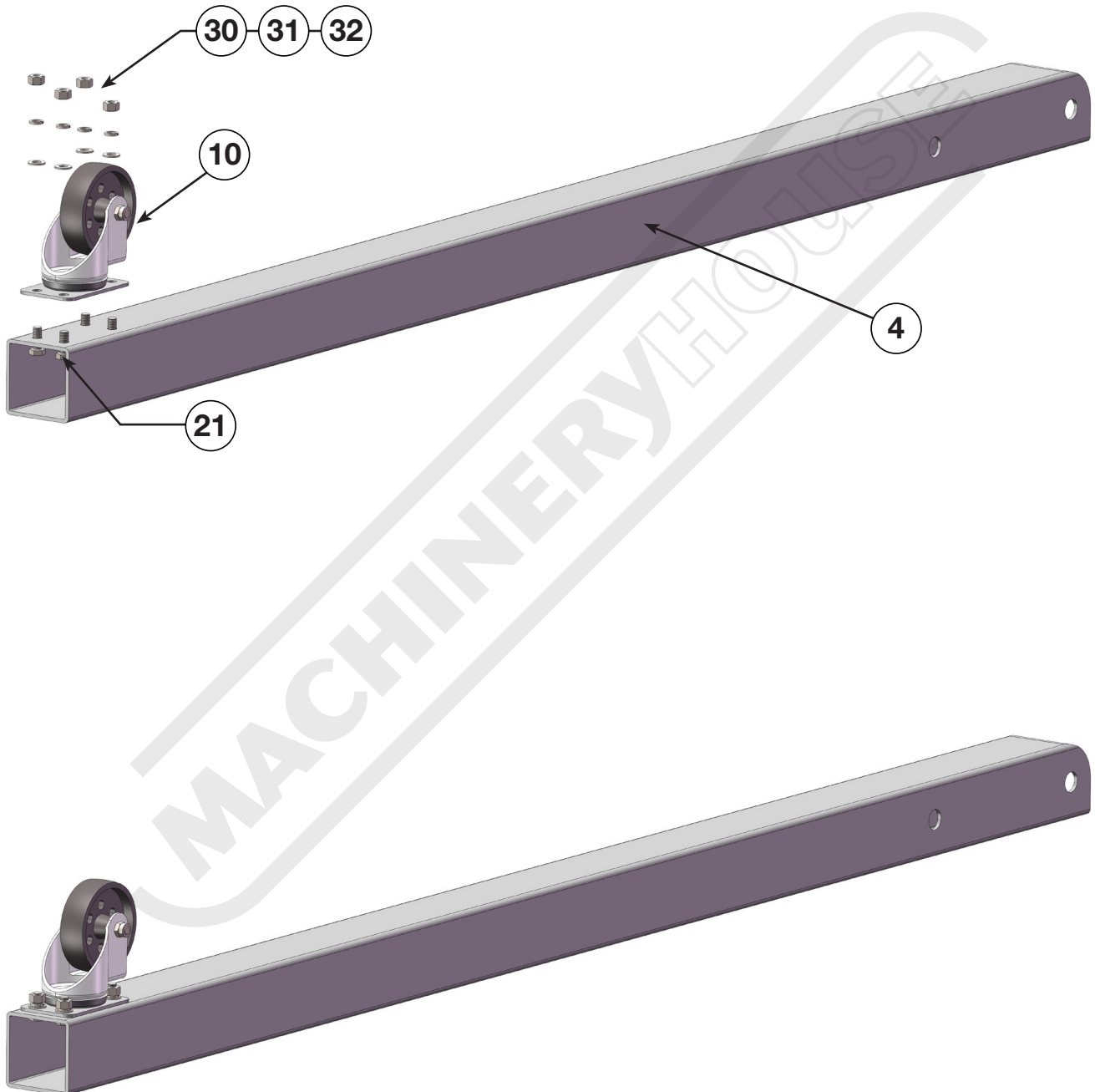



**6.0 ASSEMBLY INSTRUCTIONS****6.2**

Attached the two legs to the base by sliding one leg (#4) at a time into the base (#1) once holes are aligned secure with four lock pins (#5) and R-Pins (#7) as shown.



**6.3**

Attach the main support (#3) to the top of the base (#1) using M14x100mm bolts (#19), nuts (#23) and washers (#24) as shown.



**6.4**

Attached the two support straps (#6) to the base (#1) using M16x100mm bolts (#14), nuts (#25) and washers (#26) as shown then align the Handle (#16) to the main support (#3) and bolt together with the support straps (#6) using a M16x110mm bolt (#15), nut (#23) and washer (#24) as shown.



**6.0 ASSEMBLY INSTRUCTIONS****6.5**

Attach the bottom of the ram (#11) to the main support (#3) using a M16x90mm bolt (#17), nut (#23) and washer (#24) as shown.

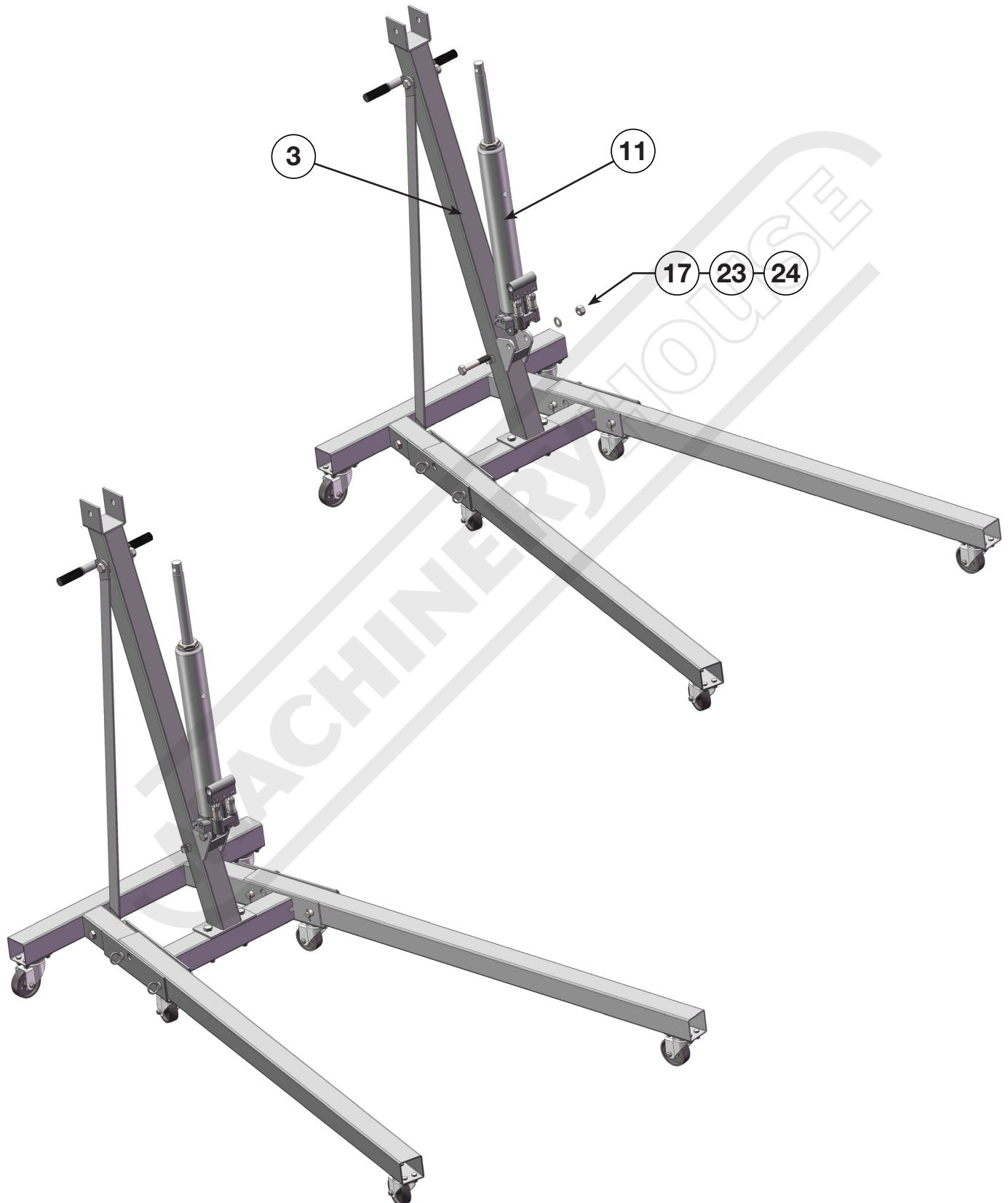

**6.0 ASSEMBLY INSTRUCTIONS**

**6.6**  
Attach the boom (#2) to the top of the main support (#3) using a M16x110mm bolt (#15), nut (#23) and washer (#24) as shown. Connect the top of the ram (#11) to the boom (#2) using a M16x80mm bolt (#18), nut (#23) and washer (#24) as shown.



- 6.7**  
Slide the boom extension (#13) into the boom (#2) at desired lifting position as secure with a M14x90mm bolt (#33), nut (#25) and washer (#26) as shown.



**6.0 ASSEMBLY INSTRUCTIONS**

**6.6**  
Attach the Lifting Shackle/Bracket (#8) to the boom extension (#13) using a M12x80mm bolt (#20), nut (#27), washer (#28) and lock washer (#29) as shown.

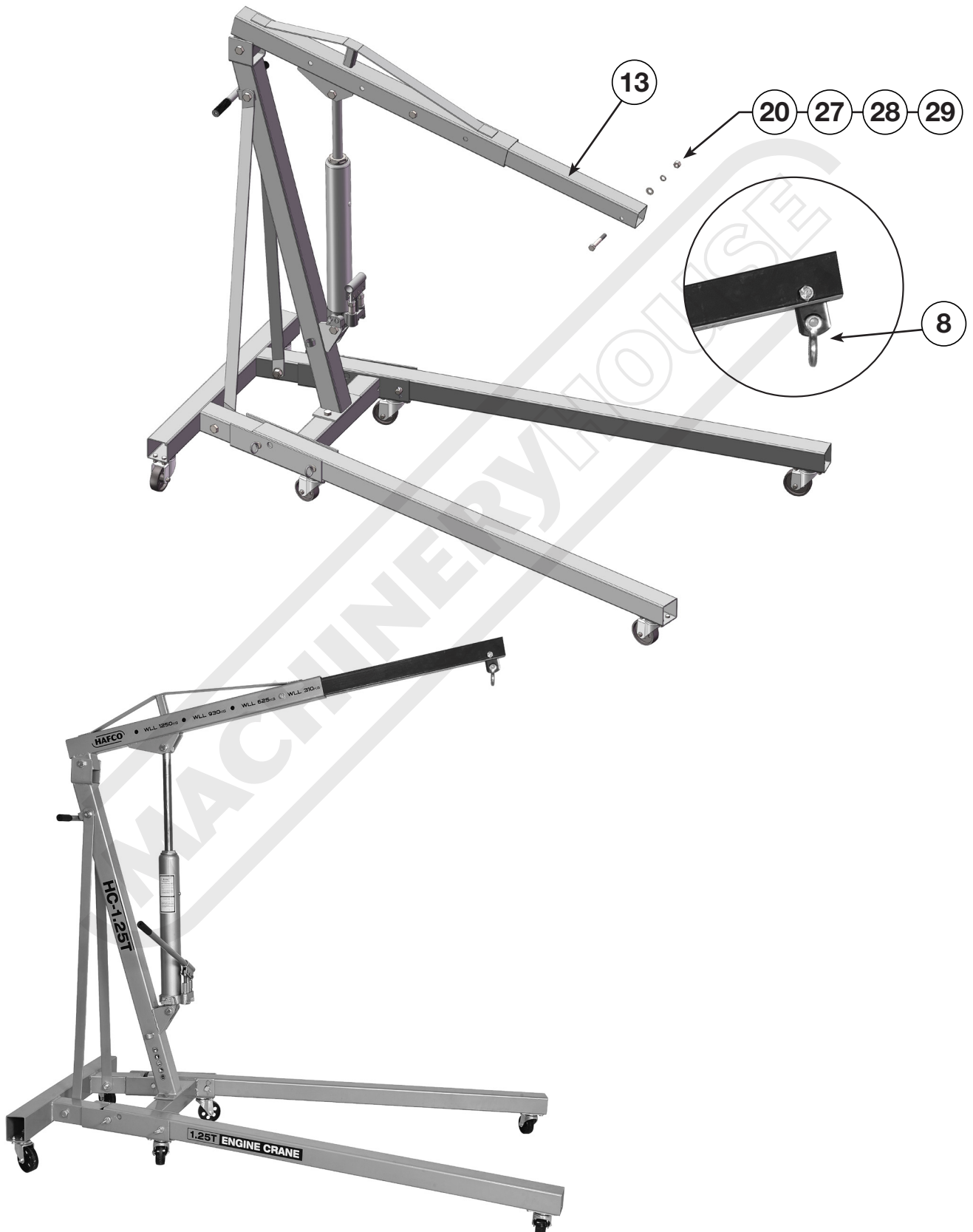



**6.7**

Insert the jack handle (#12) into the ram jack housing (#11) as shown ready for use.





## 7.0 STORING INSTRUCTIONS

**7.0**  
To fold legs up ready for storing your engine crane - remove R-Pin (#7) from one leg (#4) and remove the lock pin (#5) from hole (A). Fold leg (#4) up while supporting leg (#4) insert lock pin (#5) into hole (B), then insert R-Pin (#7) as shown. Repeat this process for the other leg. The engine crane is now ready for storing.

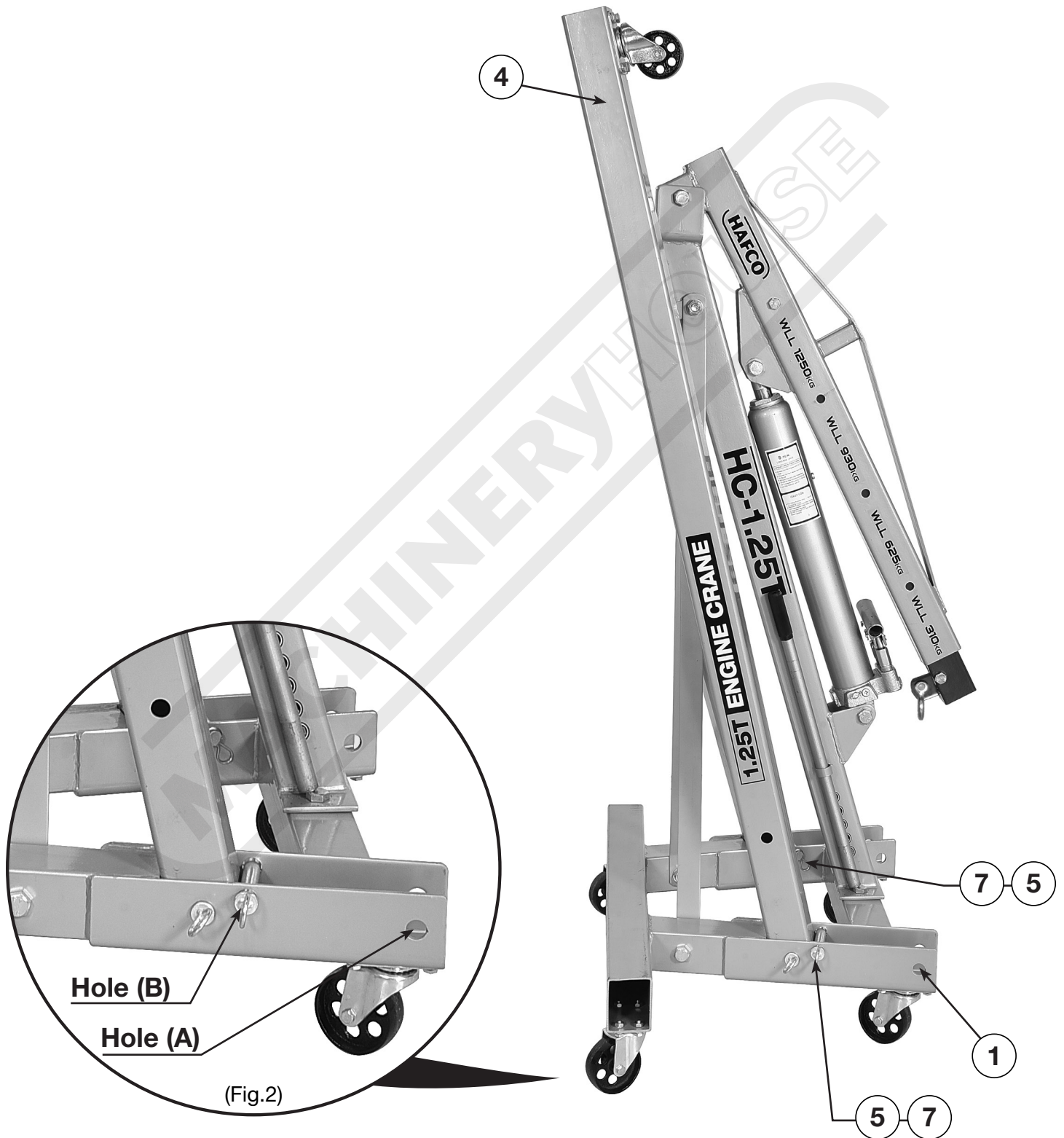

# WARNING

## General Machinery Safety Instructions

---

Machinery House  
requires you to read this entire Manual before using this machine.

- 1. Read the entire Manual before starting machinery.** Machinery may cause serious injury if not correctly used.
- 2. Always use correct hearing protection when operating machinery.** Machinery noise may cause permanent hearing damage.
- 3. Machinery must never be used when tired, or under the influence of drugs or alcohol.** When running machinery you must be alert at all times.
- 4. Wear correct Clothing.** At all times remove all loose clothing, necklaces, rings, jewelry, etc. Long hair must be contained in a hair net. Non-slip protective footwear must be worn.
- 5. Always wear correct respirators around fumes or dust when operating machinery.** Machinery fumes & dust can cause serious respiratory illness. Dust extractors must be used where applicable.
- 6. Always wear correct safety glasses.** When machining you must use the correct eye protection to prevent injuring your eyes.
- 7. Keep work clean and make sure you have good lighting.** Cluttered and dark shadows may cause accidents.
- 8. Personnel must be properly trained or well supervised when operating machinery.** Make sure you have clear and safe understanding of the machine you are operating.
- 9. Keep children and visitors away.** Make sure children and visitors are at a safe distance for your work area.
- 10. Keep your workshop childproof.** Use padlocks, Turn off master power switches and remove start switch keys.
- 11. Never leave machine unattended.** Turn power off and wait till machine has come to a complete stop before leaving the machine unattended.
- 12. Make a safe working environment.** Do not use machine in a damp, wet area, or where flammable or noxious fumes may exist.
- 13. Disconnect main power before service machine.** Make sure power switch is in the off position before re-connecting.
- 14. Use correct amperage extension cords.** Undersized extension cords overheat and lose power. Replace extension cords if they become damaged.
- 15. Keep machine well maintained.** Keep blades sharp and clean for best and safest performance. Follow instructions when lubricating and changing accessories.
- 16. Keep machine well guarded.** Make sure guards on machine are in place and are all working correctly.
- 17. Do not overreach.** Keep proper footing and balance at all times.
- 18. Secure workpiece.** Use clamps or a vice to hold the workpiece where practical. Keeping the workpiece secure will free up your hand to operate the machine and will protect hand from injury.
- 19. Check machine over before operating.** Check machine for damaged parts, loose bolts, Keys and wrenches left on machine and any other conditions that may effect the machines operation. Repair and replace damaged parts.
- 20. Use recommended accessories.** Refer to instruction manual or ask correct service officer when using accessories. The use of improper accessories may cause the risk of injury.
- 21. Do not force machinery.** Work at the speed and capacity at which the machine or accessory was designed.
- 22. Use correct lifting practice.** Always use the correct lifting methods when using machinery. Incorrect lifting methods can cause serious injury.
- 23. Lock mobile bases.** Make sure any mobile bases are locked before using machine.
- 24. Allergic reactions.** Certain metal shavings and cutting fluids may cause an allergic reaction in people and animals, especially when cutting as the fumes can be inhaled. Make sure you know what type of metal and cutting fluid you will be exposed to and how to avoid contamination.
- 25. Call for help.** If at any time you experience difficulties, stop the machine and call your nearest branch service department for help.

# WARNING

## Engine Crane Safety Instructions

---

Machinery House  
requires you to read this entire Manual before using this machine.

- 1. Maintenance.** Check oil levels and fill to correct oil levels if necessary.
- 2. Loading Requirements.** Refer to your vehicle service manual to locate the safe engine lifting/support locations, and to verify that the engine weight does not exceed the maximum engine stand load rating. Only connect lifting hooks, chains, or straps at points that can safely support the load and prevent unpredictable load swing or shift.
- 3. Engine Crane Condition.** The Engine Crane must be maintained for a proper working condition. Never operate a Engine Crane that has low oil levels, damaged or worn parts. Scheduled routine maintenance should performed on a scheduled basis. Check frame, welds, pins, wheels, chain & hook for cracks or damage. Replace if necessary.
- 4. Crushing Hazard.** Never place any part of your body in the lifting mechanism. Serious injury can occur. Never allow anyone to work under a load supported by an engine crane. Never allow the engine crane to be the sole support for the load. Use jack stands to support the load.
- 5. Work area hazards.** Keep the area around the Engine Crane clean from oil, tools, objects & chips. Pay attention to other persons in the area and know what is going on around the area to ensure unintended accidents.
- 6. Warning Labels.** Take note of any warning labels on the machine and do not remove them.
- 7. Safe Surface Use.** Only use the Engine Crane on hard, level surfaces capable of sustaining the load being lifted. Avoid using the Engine Crane on inclines or ramps that will cause a loss of control.
- 8. Safe Operation.** Load must be directly under the Engine crane before lifting. Before removing or installing your engine, always apply the handbrake and use wheel chocks to prevent vehicle from rolling. Only move the Engine Crane with the load as low as possible to the ground to prevent the Engine Crane tipping due to its high centre of gravity. Keep as much of your body as possible out from underneath the vehicle when reinstalling the engine.
- 9. Do not Modify the Engine Crane.** Never modify this engine crane or use boom extensions.
- 10. Other Hazards.** Never allow children to play on this Engine Crane, and never carry passengers!
- 11. Pinching.** Prevent pinching by releasing pressure in the ram leaving boom all the way down when not in use.
- 12. Use Correct Air Pressure** Exceeding the maximum PSI rating of Engine Crane may cause unpredictable operation, injury and damage to machine. If this rating is not stated in manual suggest NOT to exceed 125psi.  
*(Applies to Pneumatic model only).*
- 13. Disconnect Air Pressure** before servicing Engine Crane, or leaving unattended.  
*(Applies to Pneumatic model only).*
- 14. Air Hose - Trip Hazard** Hoses can easily become a tripping hazard when laid across the floor in a disorganized fashion.  
*(Applies to Pneumatic model only).*
- 15. Call for help.** If at any time you experience difficulties, stop and call you nearest branch service department for help.

# PLANT SAFETY PROGRAM

## **NEW MACHINERY HAZARD IDENTIFICATION, ASSESSMENT & CONTROL**

### **Engine Crane**

Developed in Co-operation Between A.W.I.S.A and Australia Chamber of Manufactures  
 This program is based upon the Safe Work Australia, Code of Practice - Managing Risks of Plant in the Workplace ( WHSA 2011 No10 )



Item No.	Hazard Identification	Hazard Assessment	Risk Control Strategies <small>(Recommended for Purchase / Buyer / User)</small>
B	CRUSHING	HIGH	Ensure Engine crane is on level solid ground. Ensure load is correctly slung and approved sling, chains etc are used. Keep body clear from under load. Do not exceed maximum lifting capacity. Wear safety boots. Always check around load before lowering. Check engine crane and lifting equipment for damage etc prior to use. Ensure load is lowered smoothly. Do not exceed recommended maximum PSI rating. (applies to Pneumatic model only)
D	SHEARING	MEDIUM	Keep body parts clear between moving components of engine crane when lowering.
G	HIGH PRESSURE AIR	MEDIUM	Disconnect air supply to engine crane prior to checks or maintenance. Do not exceed recommended maximum PSI rating. (applies to Pneumatic model only)
J	SLIPPING, TRIPPING, & FALLING	LOW	Avoid uneven or slippery surfaces when moving engine crane under load.
Plant Safety Program to be read in conjunction with manufactures instructions			



[www.machineryhouse.com.au](http://www.machineryhouse.com.au)



[www.machineryhouse.co.nz](http://www.machineryhouse.co.nz)

Authorised and signed by:   
 Safety officer:   
 Manager: 

Revised Date: 4th December 2017



### ENVIRONMENT PROTECTION

Recycle unwanted materials instead of disposing of them as waste. All tools, accessories and packaging should be sorted, taken to a recycling centre and disposed of in a manner which is compatible with the environment. When the product becomes completely unserviceable and requires disposal, drain any fluids (if applicable) into approved containers and dispose of the product and fluids according to local regulations.

Imported by

**HARE & FORBES**  
**MACHINERYHOUSE**

Australian Distributor

**Hare & Forbes**  
**Machineryhouse**  
Sydney - Melbourne  
Adelaide - Brisbane - Perth

Ph: 1300 202 200  
[www.machineryhouse.com.au](http://www.machineryhouse.com.au)

**MACHINERYHOUSE**

New Zealand Distributor

**Machineryhouse**  
Auckland  
Christchurch

Ph: 0800 142 326  
[www.machineryhouse.co.nz](http://www.machineryhouse.co.nz)